



# EZT3E/F 'Easy Cal' CiTiceL®

Low range 4-20mA Microprocessor Transmitter

## Performance Characteristics

<b>Sensor Type Used</b>	3E/F
<b>Inboard Filter</b>	To remove H <sub>2</sub> S and SO <sub>2</sub>
<b>Expected Operating Life</b>	Three years in air
<b>Resolution</b>	0.5ppm
<b>Temperature Range</b>	-20°C to +50°C
<b>Pressure Range</b>	Atmospheric ± 10%
<b>Pressure Coefficient</b>	0.020 ± 0.008% signal/mBar
<b>T<sub>90</sub> Response Time</b>	<30 seconds
<b>Relative Humidity Range</b>	15 to 90% non-condensing
<b>Maximum Zero Shift (+20°C to +40°C)</b>	9ppm equivalent
<b>Long Term Output Drift</b>	<5% signal loss/year
<b>Repeatability</b>	1% of signal
<b>Output Linearity</b>	Linear

N.B. All performance data is based on conditions at 20°C, 50%RH, and 1013mBar

## Electrical Properties

<b>Minimum Input Span</b>	5uA
<b>Maximum Input Span</b>	±100uA
<b>Linearity @ 25°C</b>	0.01% Full Scale
<b>Thermal Drift (Input)</b>	0.02% per °C
<b>Linearisation</b>	Linear Response
<b>Output</b>	4/20mA, 2 wire loop powered
<b>Max Output Range</b>	3.8 to 21mA
<b>Operating Voltage</b>	10 to 30VDC
<b>Thermal Drift (Output)</b>	2uA per °C
<b>Output Accuracy</b>	±5uA
<b>Protection</b>	Reverse Polarity Protected
<b>Maximum Loop Load</b>	$R_{LOAD} = (V_{supply} - 10) * 50$ eg 700Ω at 24V

## Outline Dimensions

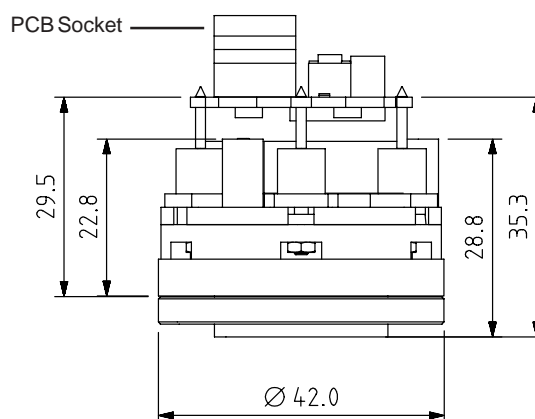

## Ranges Available

3E/F CiTiceL 'Easy Cal' 4-20mA Transmitters are available with the following precalibrated ranges:

Range	Order Code
0-50ppm .....	2TB7E-1A
0-100ppm .....	2TB7F-1A
0-200ppm .....	2TB7G-1A
0-300ppm .....	2TB7H-1A
0-500ppm .....	2TB7I-1A

## Physical Characteristics

<b>Weight</b>	58g (incl. mounting accessory)
<b>Position Sensitivity</b>	None
<b>Storage Life</b>	Six months in CTL container
<b>Recommended Storage Temperature</b>	0-20°C
<b>Warranty Period</b>	12 months from date of despatch

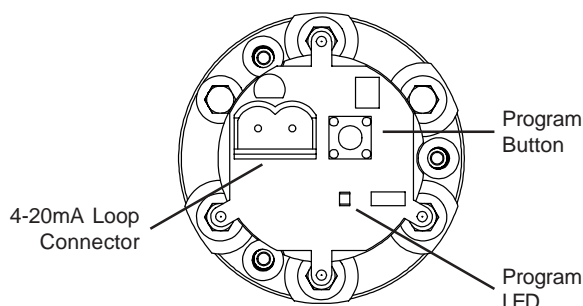

### **Calibration notes**

Recalibration is only possible if the output of the sensor at full scale is greater than 50% of the original factory calibration. Failure can occur if:

1. Attempts to recalibrate to a range less than 50% of the original factory calibrated range
2. The output of the sensor has fallen by more than 50% (replace sensor)
3. Incorrect span gas used (use correct span gas)
4. Insufficient time for output to settle after exposing sensor to span gas (apply span gas for 2-5 mins before setting 20mA level)

### **Transmitter Error Condition**

Any time the error condition is set the output will be forced to 21mA and the LED will be held on. Carry out the Reset function to reset the error.

### **Reset to Factory Calibration**

1. Remove loop power from transmitter.
2. Hold down push button and connect loop power to transmitter.
3. LED will blink as soon as power is applied (approx. 2Hz).
4. Transmitter output set to 21mA.
5. Releasing button will start an 8 second timeout period.
6. After 8 seconds the factory calibration will overwrite user calibration.
7. LED clears and transmitter goes back into normal mode.

### **User Calibration Method**

(Span gas = 20mA signal)

1. Connect loop power to the transmitter.
2. Apply required zero gas/air to transmitter for 2 minutes.
3. Hold down button until LED flashes at approx. 1Hz. (4mA level now set)
4. Apply required span gas to transmitter for 2 to 5 minutes.
5. Press and release button (20mA level now set)
6. There will be an 8-second timeout period and flashing LED approx. 8Hz.
7. Calibration is complete, LED clears and returns to normal mode.

### **Non Standard Span Gas Calibration**

(Span gas  $\pm 5\%$  full range)

1. Calculate the mA signal expected for span gas.  
*Example:*  
Required 4-20mA range is 0-500ppm  
Available span gas is 480ppm  
Dynamic range is 16mA  
Therefore 1mA = 31.25ppm  
Expected signal at 480ppm = (15.36mA + 4mA) = 19.36mA  
Each time button is pressed signal increases by 40uA. When the output reaches 20.8mA the next button press will take the output to 19.2mA. Further button presses will again increase the output by 40uA.  
The output range available is 19.2mA to 20.8mA.
2. Carry out steps 1-4 of User Calibration Method
3. Press and release button to set 20mA level.
4. Continued momentary pressing of the button within an eight second period will trim the output by 40uA. When the required output is reached, allow the transmitter to timeout.
5. Calibration is complete, LED clears and returns to normal mode.



### Non Standard Span Gas Calibration

(Span gas not within  $\pm 5\%$  of full range)  
(current source required)

1. Measure the current of the sensor with a known gas concentration. This can then be used to calculate the  $\mu\text{A/ppm}$  for the specific sensor.
2. Now calculate the expected current when the sensor is exposed to the full scale of target gas.

*Example:*

Required 4-20mA range is 0-500ppm  
Available span gas is 300ppm  
Current from sensor when exposed to span gas = 33uA  
Therefore sensitivity = 0.11 uA/ppm  
Expected sensor output at 500ppm = 55uA

3. Connect current loop power to the transmitter.
4. Connect a current source to the transmitter.  
For oxidising sensors ( $\text{CO}$ ,  $\text{H}_2\text{S}$ ,  $\text{SO}_2$ ,  $\text{NO}$ , ...) connect the negative to 'SEN' and positive to 'CNT'.  
For reducing sensors ( $\text{Cl}_2$  or  $\text{NO}_2$ ) connect the positive to 'SEN' and negative to 'CNT'.  
'CNT' and 'REF' terminals on the transmitter board should be connected.
5. Set the current source to zero.
6. Hold down button until LED flashes at approx. 1Hz. (4mA level now set in RAM)
7. Set the current source to the value calculated for the full scale of target gas.
8. Press and release button (20mA level now set into RAM)
9. There will be an 8-second timeout period and flashing LED approx. 8Hz.
10. Calibration is complete, LED clears and returns to normal mode.

### Mounting

A diffusion mounting assembly, the "nose" adaptor, is supplied with CiTiceL transmitters for convenient mounting in a wide range of weatherproof housings. The nose adaptor requires a 25mm diameter hole in the outside wall of the housing to allow installation. The assembly is shown below.

The Mounting Nose also features a plug for easy zeroing and exposure to gas during calibration. A bonded membrane and mesh is included to prevent the ingress of dirt and dust particles to the CiTiceL.

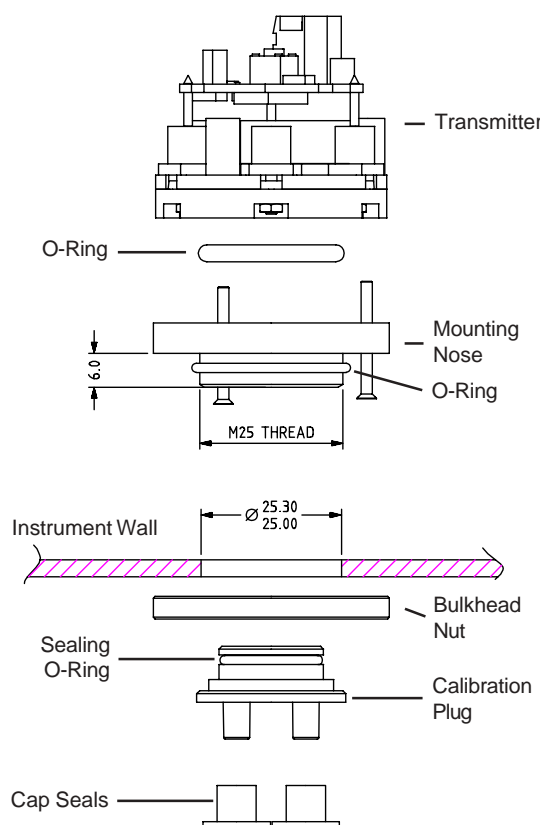



### Temperature Dependence

The output of a CiTiceL can vary with temperature. The graph here shows the variation in output with temperature for 3E/F CiTiceLs based on a sample of about 16 sensors. The results are shown in the graph as a mean for the batch, and expressed as a percentage of the signal at 20°C.

From a statistical viewpoint, for a sample of this size, the range in values observed for all sensors of this type will fall within a range three times the standard deviation above or below the mean. Assuming therefore this sample is typical, then the temperature behaviour of all 3E/F CiTiceLs will fall in the band +3SD to -3SD.

### 3E/F Temperature Coefficient Data

Temp vs Signal

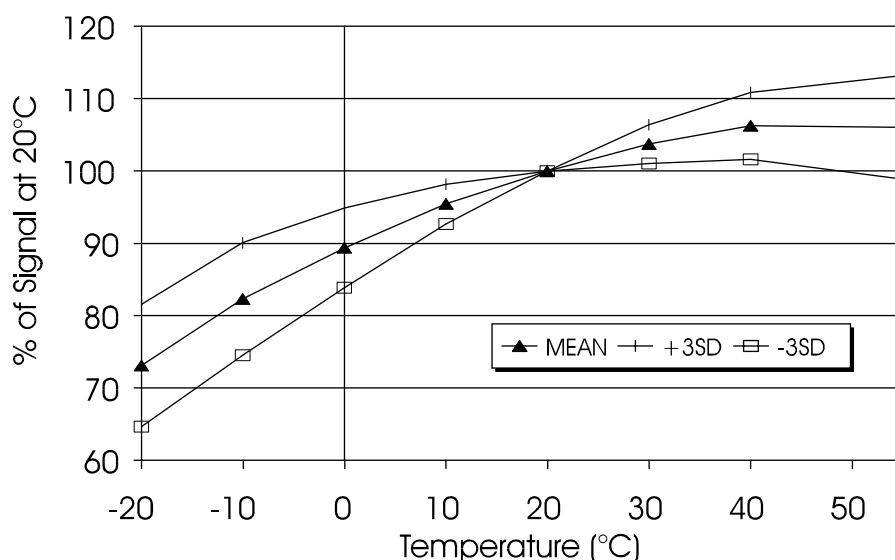

### Cross-sensitivity Data

CiTiceLs may exhibit a response to certain gases in a sample other than the target gas. 3E/F CiTiceLs have been tested with a number of commonly cross-interfering gases and the results expressed below as the typical response to be expected from a sensor when exposed to a given test gas concentration (relevant to safety, e.g. TLV levels).

Gas	Conc.	3E/F	Gas	Conc.	3E/F
Hydrogen sulphide:	15ppm	≈1ppm	Sulphur dioxide:	5ppm	0ppm
Nitric oxide:	35ppm	<3.5ppm	Nitrogen dioxide:	5ppm	0ppm
Chlorine:	1ppm	0ppm	Hydrogen:	100ppm	<60ppm
Hydrogen cyanide:	10ppm	0ppm	Hydrogen chloride:	5ppm	0ppm
Ethylene:	100ppm	<75ppm			

\*\*For details of other possible cross-interfering gases contact City Technology\*\*

Every effort has been made to ensure the accuracy of this document at the time of printing. In accordance with the company's policy of continued product improvement City Technology Limited reserves the right to make product changes without notice. No liability is accepted for any consequential losses, injury or damage resulting from the use of this document or from any omissions or errors herein. The data is given for guidance only. It does not constitute a specification or an offer for sale. The products are always subject to a programme of improvement and testing which may result in some changes in the characteristics quoted. As the products may be used by the client in circumstances beyond the knowledge and control of City Technology Limited, we cannot give any warranty as to the relevance of these particulars to an application. It is the clients' responsibility to carry out the necessary tests to determine the usefulness of the products and to ensure their safety of operation in a particular application.

Performance characteristics on this data sheet outline the performance of newly supplied sensors. Output signal can drift below the lower limit over time.