

Product specification of:

Industrial O₂-Sensor**Type: FOS - 65**

Part. No.: 41 00 21

Key features: fast oxygen sensor giving response in milliseconds that does not require any additional accelerating electronics to reach performance.

All characteristics are based on conditions at 25°C, 50 % RH and 1013 hPa

Operating Principle:	galvanic fuel cell
Measurement Range:	0 - 65 Vol. %
Electrical Connector:	3-pin Molex
Nominal Sensor Life:	= 150, 000% hours O ₂
Expected Operating Life:	1 year @ ambient air
Output Signal:	25 mV ± 5 mV @ ambient air
Response Time t ₉₀ :	< 150 ms
Short-term Drift:	< 1 % volume O ₂ per day
Operating Temperature:	0 - 45 °C
Pressure Range:	600 - 1750 hPa
Linearity Error:	< 2 % @ 65 Vol. %
Zero Offset Voltage:	100 µV in 100 % N ₂ , applied for 1 minute
Influence of Humidity:	- 0.03 % relative O ₂ reading per % RH
Temperature Compensation:	NTC
Interferences:	< 0.3 % O ₂ response to: 80.0 % N ₂ O balance N ₂ 7.5 % Halothane balance N ₂ 7.5 % Isoflurane balance N ₂ 7.5 % Isoflurane balance N ₂ 7.5 % Enflurane balance N ₂ 9.0 % Sevoflurane balance N ₂ 20.0 % Desflurane balance N ₂ 10.0 % CO ₂ balance N ₂

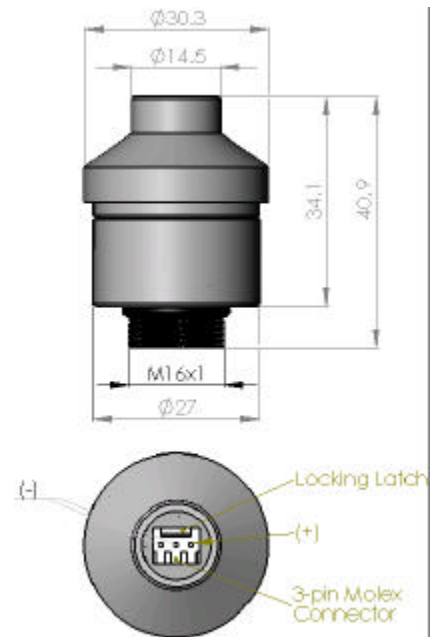

Tolerance: ± 0.15 mm

Storage Conditions

Temperature Range:	maximum: -20 - 55 °C recommended: 5 - 30 °C
Ambient Pressure:	600 - 1750 hPa
Humidity:	up to 100 % RH
Shelf Life:	not more than 3 months recommended
Weight:	approximately 24 g
Material in contact with media:	PA12, PPS, PTFE, stainless steel
Warranty Period:	6 months
Housing Colour:	black

This data sheet is subject to change without prior notice !

[FOS-65 Rev. 02-05.doc]

page 1/1

IT Dr. Gambert GmbH, Hinter dem Chor 21, 23966 Wismar, Germany

Tel.: +49 (0) 3841 22 00 50, Fax: +49 (0) 3841 22 00 522, sales@it-wismar.de, www.it-wismar.de