



# A3ME/D mV Output CiTiceL

The A3E/D Carbon Monoxide CiTiceL is available with a precalibrated mV/ppm output, known as the A3ME/D. This option combines a standard A3E/D CiTiceL with a low power surface mount design printed circuit board to convert the micro-amp level signal.

## Performance Characteristics

<b>Sensor Type Used</b>	A3E/D
<b>Expected Operating Life</b>	Two years in air
<b>Output Signal</b>	1mV/ppm (±5%)
<b>Maximum Range</b>	0-4000ppm
<b>Inboard Filter</b>	To remove acid gases
<b>Auxiliary Electrode</b>	To compensate for H <sub>2</sub> cross-interference
<b>Maximum Zero Output</b>	0 ± 1mV
<b>Maximum Zero Shift (+20°C to +40°C)</b>	3ppm equivalent
<b>Temperature Range</b>	-20°C to +50°C
<b>Pressure Range</b>	Atmospheric ± 10%
<b>Pressure Coefficient</b>	0.02% signal/mBar
<b>T<sub>90</sub> Response Time</b>	<38 seconds
<b>Relative Humidity Range</b>	15 to 90% non-condensing
<b>Long Term Output Drift</b>	<2% of full signal/month
<b>Repeatability</b>	<1% of signal
<b>Output Linearity</b>	Linear

**N.B.** All performance data is based on conditions at 20°C, 50%RH, and 1013mBar

## Physical Characteristics

<b>Weight</b>	34g (incl. leads)
<b>Position Sensitivity</b>	None
<b>Storage Life</b>	Six months in CTL container
<b>Recommended Storage Temperature</b>	0-20°C
<b>Warranty Period</b>	12 months from date of despatch

## Electrical Properties

<b>Power Supply Required</b>	Recommended 9V d.c. Limits 3-10V d.c.
<b>Power Consumption</b>	500 μA quiescent
<b>Calibration</b>	Via built-in span and zero potentiometers

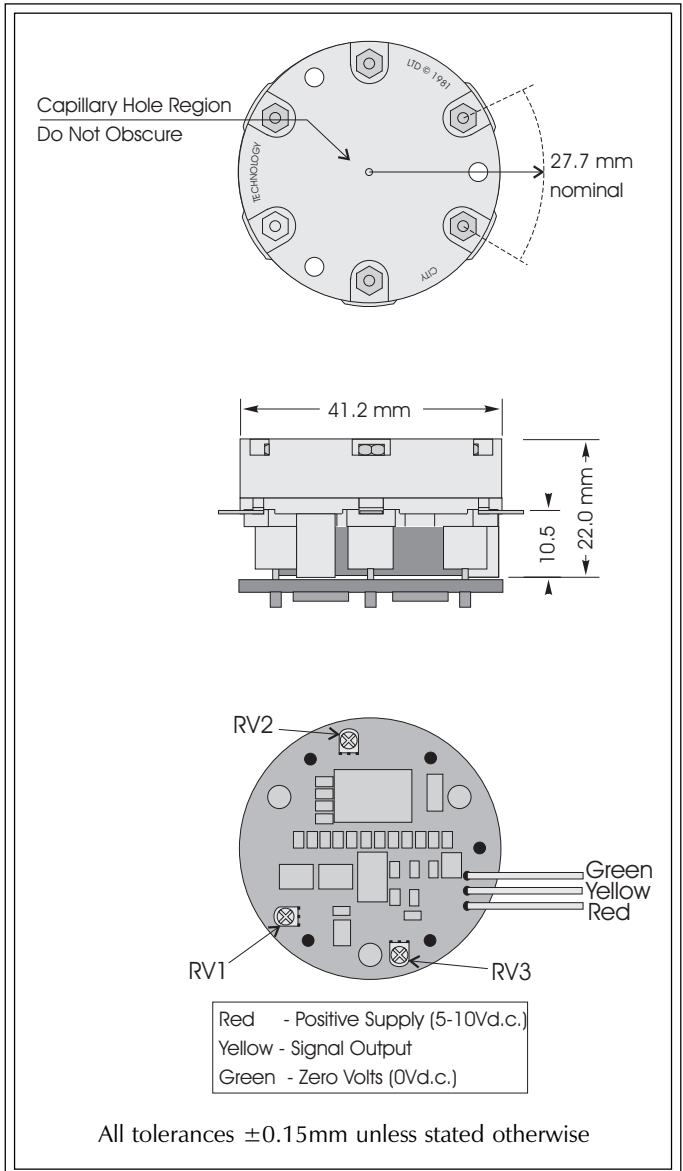



## Temperature Dependence

The output of a CiTiceL can vary with temperature. As the operation of the A3E/D CiTiceL is different to that of standard CiTiceLs, the temperature behaviour of these sensors is very different. It cannot therefore be represented in the standard graph format, but details can be obtained from City Technology.

## Cross-sensitivity Data

CiTiceLs may exhibit a response to certain gases in a sample other than the target gas. The table below shows the typical response of A3E/D sensors to a number of common cross-interfering gases. The figures are expressed as a percentage of the primary sensitivity (i.e. carbon monoxide = 100%).

<b>Gas</b>	<b>Response</b>	<b>Gas</b>	<b>Response</b>
<b>Hydrogen sulphide:</b>	0	<b>Hydrogen:</b>	<1 (see note)
<b>Sulphur dioxide:</b>	0	<b>Hydrogen chloride:</b>	0
<b>Nitric oxide:</b>	0	<b>Ethylene:</b>	≈35
<b>Nitrogen dioxide:</b>	0	** For details of other possible cross-interfering gases contact City Technology.**	

**Note:** Cross-sensitivity to H<sub>2</sub> <1% after compensation

## Ordering Information

mV Output A3E/D CiTiceL ..... A3ME/D

Every effort has been made to ensure the accuracy of this document at the time of printing. In accordance with the company's policy of continued product improvement City Technology Limited reserves the right to make product changes without notice. No liability is accepted for any consequential losses, injury or damage resulting from the use of this document or from any omissions or errors herein. The data is given for guidance only. It does not constitute a specification or an offer for sale. The products are always subject to a programme of improvement and testing which may result in some changes in the characteristics quoted. As the products may be used by the client in circumstances beyond the knowledge and control of City Technology Limited, we cannot give any warranty as to the relevance of these particulars to an application. It is the clients' responsibility to carry out the necessary tests to determine the usefulness of the products and to ensure their safety of operation in a particular application. Performance characteristics on this data sheet outline the performance of newly supplied sensors. Output signal can drift below the lower limit over time.