



EZT3F/F 'Easy Cal' CiTiceL®

High range 4-20mA Microprocessor Transmitter

Performance Characteristics

Sensor Type Used	3F/F
Inboard Filter	To remove acid gases from flue stream
Filter Life	560,000 ppm hours *see Note
Expected Operating Life	Three years in air
Resolution	1ppm
Temperature Range	-20°C to +50°C
Pressure Range	Atmospheric ± 10%
Pressure Coefficient	0.007 ± 0.003% signal/mBar
T₉₀ Response Time	<30 seconds
Relative Humidity Range	15 to 90% non-condensing
Maximum Zero Shift (+20°C to +40°C)	20ppmequivalent
Long Term Output Drift	<2% signal loss/year
Repeatability	1% of signal
Output Linearity	Linear

Note NO removal based on continuous exposure to 1000ppm and 5% breakthrough

N.B. All performance data is based on conditions at 20°C, 50%RH, and 1013mBar

Electrical Properties

Minimum Input Span	5uA
Maximum Input Span	±100uA
Linearity @ 25°C	0.01% Full Scale
Thermal Drift (Input)	0.02% per °C
Linearisation	Linear Response
Output	4/20mA, 2 wire loop powered
Max Output Range	3.8 to 21mA
Operating Voltage	10 to 30VDC
Thermal Drift (Output)	2uA per °C
Output Accuracy	±5uA
Protection	Reverse Polarity Protected
Maximum Loop Load	$R_{LOAD} = (V_{supply} - 10) * 50$ eg 700Ω at 24V

Outline Dimensions

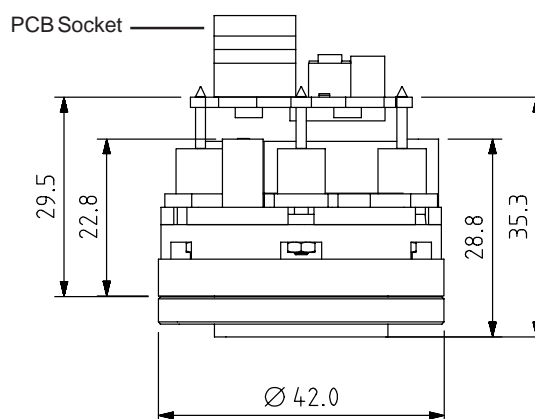

Ranges Available

3F/F CiTiceL 'Easy Cal' 4-20mA Transmitters are available with the following precalibrated ranges:

Range	Order Code
0-500ppm	2TBAL-1A
0-1000ppm	2TBAJ-1A
0-2000ppm	2TBAK-1A

Physical Characteristics

Weight	58g (incl. mounting accessory)
Position Sensitivity	None
Storage Life	Six months in CTL container
Recommended Storage Temperature	0-20°C
Warranty Period	12 months from date of despatch

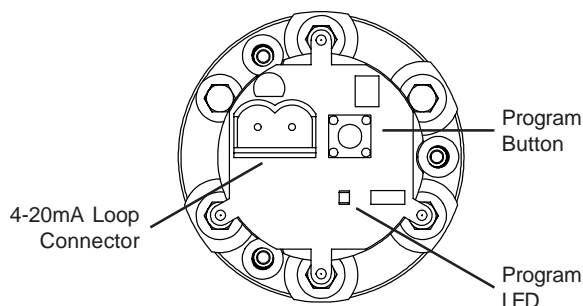

Calibration notes

Recalibration is only possible if the output of the sensor at full scale is greater than 50% of the original factory calibration. Failure can occur if:

1. Attempts to recalibrate to a range less than 50% of the original factory calibrated range
2. The output of the sensor has fallen by more than 50% (replace sensor)
3. Incorrect span gas used (use correct span gas)
4. Insufficient time for output to settle after exposing sensor to span gas (apply span gas for 2-5 mins before setting 20mA level)

Transmitter Error Condition

Any time the error condition is set the output will be forced to 21mA and the LED will be held on. Carry out the Reset function to reset the error.

Reset to Factory Calibration

1. Remove loop power from transmitter.
2. Hold down push button and connect loop power to transmitter.
3. LED will blink as soon as power is applied (approx. 2Hz).
4. Transmitter output set to 21mA.
5. Releasing button will start an 8 second timeout period.
6. After 8 seconds the factory calibration will overwrite user calibration.
7. LED clears and transmitter goes back into normal mode.

User Calibration Method

(Span gas = 20mA signal)

1. Connect loop power to the transmitter.
2. Apply required zero gas/air to transmitter for 2 minutes.
3. Hold down button until LED flashes at approx. 1Hz. (4mA level now set)
4. Apply required span gas to transmitter for 2 to 5 minutes.
5. Press and release button (20mA level now set)
6. There will be an 8-second timeout period and flashing LED approx. 8Hz.
7. Calibration is complete, LED clears and returns to normal mode.

Non Standard Span Gas Calibration

(Span gas $\pm 5\%$ full range)

1. Calculate the mA signal expected for span gas.
Example:
Required 4-20mA range is 0-500ppm
Available span gas is 480ppm
Dynamic range is 16mA
Therefore 1mA = 31.25ppm
Expected signal at 480ppm = (15.36mA + 4mA) = 19.36mA
Each time button is pressed signal increases by 40uA. When the output reaches 20.8mA the next button press will take the output to 19.2mA. Further button presses will again increase the output by 40uA.
The output range available is 19.2mA to 20.8mA.
2. Carry out steps 1-4 of User Calibration Method
3. Press and release button to set 20mA level.
4. Continued momentary pressing of the button within an eight second period will trim the output by 40uA. When the required output is reached, allow the transmitter to timeout.
5. Calibration is complete, LED clears and returns to normal mode.



Non Standard Span Gas Calibration

(Span gas not within $\pm 5\%$ of full range)
(current source required)

1. Measure the current of the sensor with a known gas concentration. This can then be used to calculate the $\mu\text{A/ppm}$ for the specific sensor.
2. Now calculate the expected current when the sensor is exposed to the full scale of target gas.

Example:

Required 4-20mA range is 0-500ppm
Available span gas is 300ppm
Current from sensor when exposed to span gas = 33 μA
Therefore sensitivity = 0.11 $\mu\text{A/ppm}$
Expected sensor output at 500ppm = 55 μA

3. Connect current loop power to the transmitter.
4. Connect a current source to the transmitter.
For oxidising sensors (CO , H_2S , SO_2 , NO , ...) connect the negative to 'SEN' and positive to 'CNT'.
For reducing sensors (Cl_2 or NO_2) connect the positive to 'SEN' and negative to 'CNT'.
'CNT' and 'REF' terminals on the transmitter board should be connected.
5. Set the current source to zero.
6. Hold down button until LED flashes at approx. 1Hz. (4mA level now set in RAM)
7. Set the current source to the value calculated for the full scale of target gas.
8. Press and release button (20mA level now set into RAM)
9. There will be an 8-second timeout period and flashing LED approx. 8Hz.
10. Calibration is complete, LED clears and returns to normal mode.

Mounting

A diffusion mounting assembly, the "nose" adaptor, is supplied with CiTiceL transmitters for convenient mounting in a wide range of weatherproof housings. The nose adaptor requires a 25mm diameter hole in the outside wall of the housing to allow installation. The assembly is shown below.

The Mounting Nose also features a plug for easy zeroing and exposure to gas during calibration. A bonded membrane and mesh is included to prevent the ingress of dirt and dust particles to the CiTiceL.

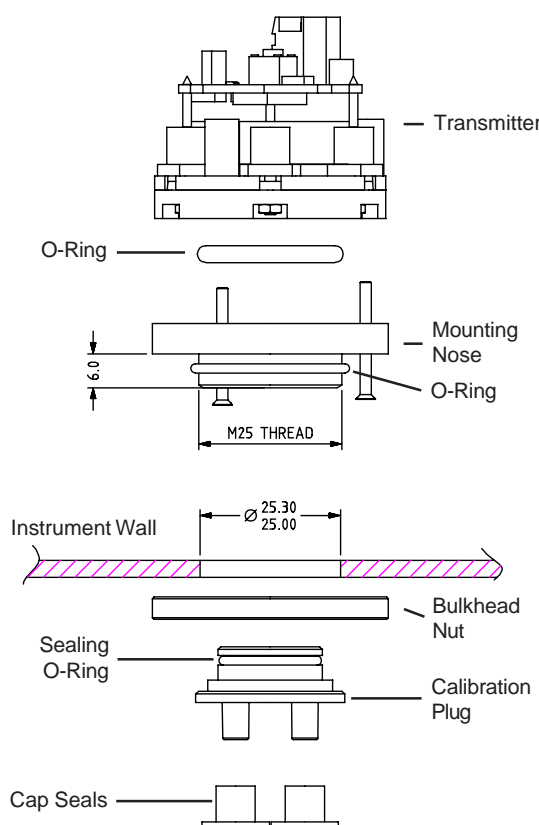



3F/F Carbon Monoxide - Output vs Temperature

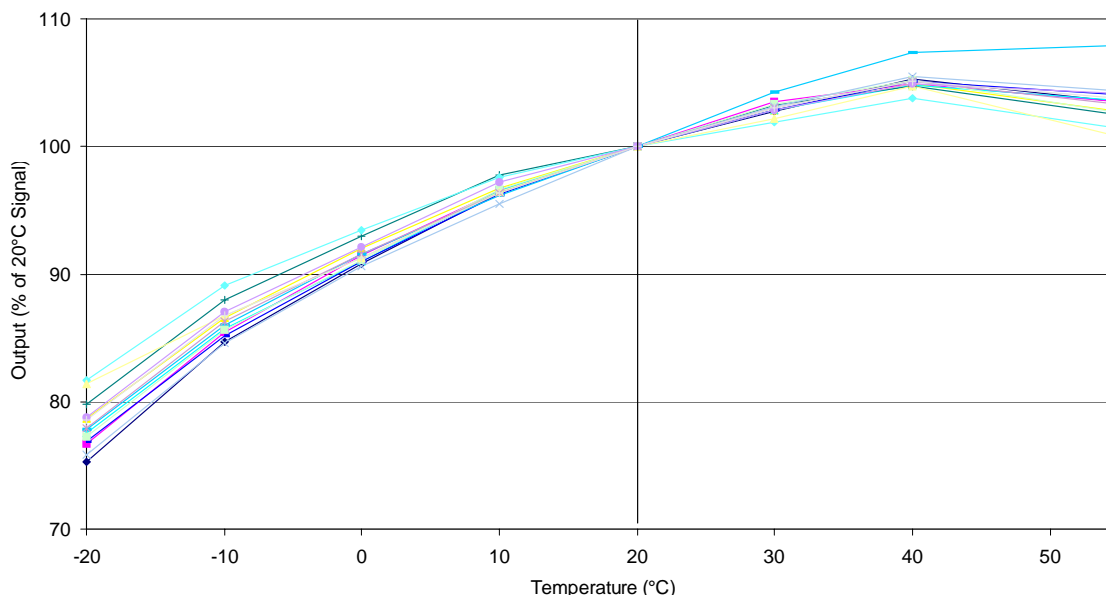

Cross-sensitivity Data

CiTiceLs may exhibit a response to certain gases in a sample other than the target gas. 3F/F CiTiceLs have been tested with a number of commonly cross-interfering gases and the results are given below. The table shows the typical response to be expected from a sensor when exposed to a given test gas concentration (relevant to safety, e.g. TLV levels).

<u>Gas</u>	<u>Conc.</u>	<u>3F/F</u>	<u>Gas</u>	<u>Conc.</u>	<u>3F/F</u>
Hydrogen sulphide:	15ppm	0ppm	Sulphur dioxide:	5ppm	0ppm
Nitric oxide:	50ppm	-1<x\$<0ppm	Nitrogen dioxide:	5ppm	0ppm
Hydrogen:	100ppm	<60ppm ¹	Hydrogen chloride:	5ppm	0ppm
Ethylene:	100ppm	0<x\$<20ppm			

¹For applications where a hydrogen compensated output is required the A3E/D CiTiceL should be used

For details of other possible cross-interfering gases contact City Technology.

Every effort has been made to ensure the accuracy of this document at the time of printing. In accordance with the company's policy of continued product improvement City Technology Limited reserves the right to make product changes without notice. No liability is accepted for any consequential losses, injury or damage resulting from the use of this document or from any omissions or errors herein. The data is given for guidance only. It does not constitute a specification or an offer for sale. The products are always subject to a programme of improvement and testing which may result in some changes in the characteristics quoted. As the products may be used by the client in circumstances beyond the knowledge and control of City Technology Limited, we cannot give any warranty as to the relevance of these particulars to an application. It is the clients' responsibility to carry out the necessary tests to determine the usefulness of the products and to ensure their safety of operation in a particular application.

Performance characteristics on this data sheet outline the performance of newly supplied sensors. Output signal can drift below the lower limit over time.