

Performance Characteristics

Nominal Range	0-5000ppm
Maximum Overload	10000ppm
Inboard Filter	To remove effect of SO ₂ in flue stream
Expected Operating Life	Two years in air
Output Signal	0.03 ± 0.01 µA/ppm
Resolution	5ppm
Temperature Range	-20°C to +50°C
Pressure Range	Atmospheric ± 10%
Pressure Coefficient	0.01% signal/mBar
T₉₀ Response Time	≤15 seconds
Relative Humidity Range	15 to 90% non-condensing
Typical Baseline Range (pure air)	0 to +50ppm equivalent
Maximum Zero Shift (+20°C to +40°C)	30ppm equivalent
Long Term Output Drift	<2% signal loss/month
Recommended Load Resistor	10 Ω
Bias Voltage	+300mV
Repeatability	2% of signal
Output Linearity	Linear

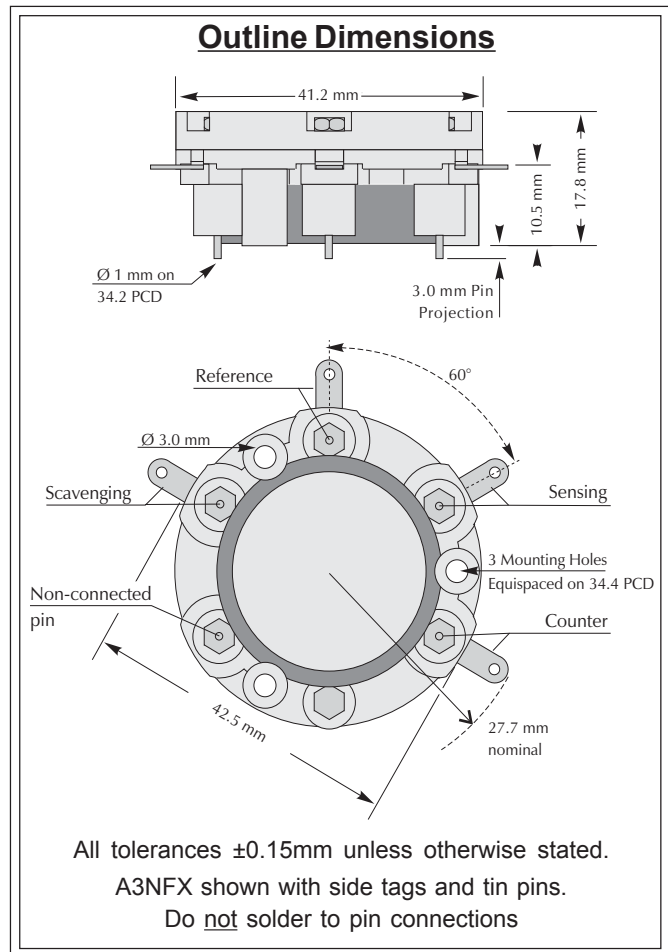

Ordering Information

N.B. All performance data is based on conditions at 20°C, 50%RH, and 1013mBar

The A3NFX Nitric Oxide CiTiceL is available with side tags, gold-plated PCB pins, or both PCB pins and side tags. To ensure the appropriate option is supplied care must be taken to provide the correct code when ordering.

Physical Characteristics

Weight	22g
Position Sensitivity	None
Storage Life	Six months in CTL container
Recommended Storage Temperature	0-20°C
Warranty Period	12 months from date of despatch

Type A3NFX:-
With side tag and PCB pin connections -**A3NFX**



Cross-sensitivity Data

CiTiceLs may exhibit a response to certain gases in a sample other than the target gas. The table below shows the typical response of A3NFX sensors to a number of common cross-interfering gases. The figures are expressed as a percentage of the primary sensitivity (i.e. nitric oxide = 100%).

Gas	Response	Gas	Response
Carbon monoxide:	0	Hydrogen:	0
Hydrogen sulphide:	0	Hydrogen chloride:	<5
Sulphur dioxide:	0	Ethylene:	0
Nitrogen dioxide:	<10		

** For details of other possible cross-interfering gases contact City Technology.**

Recommended circuit for A3NFX

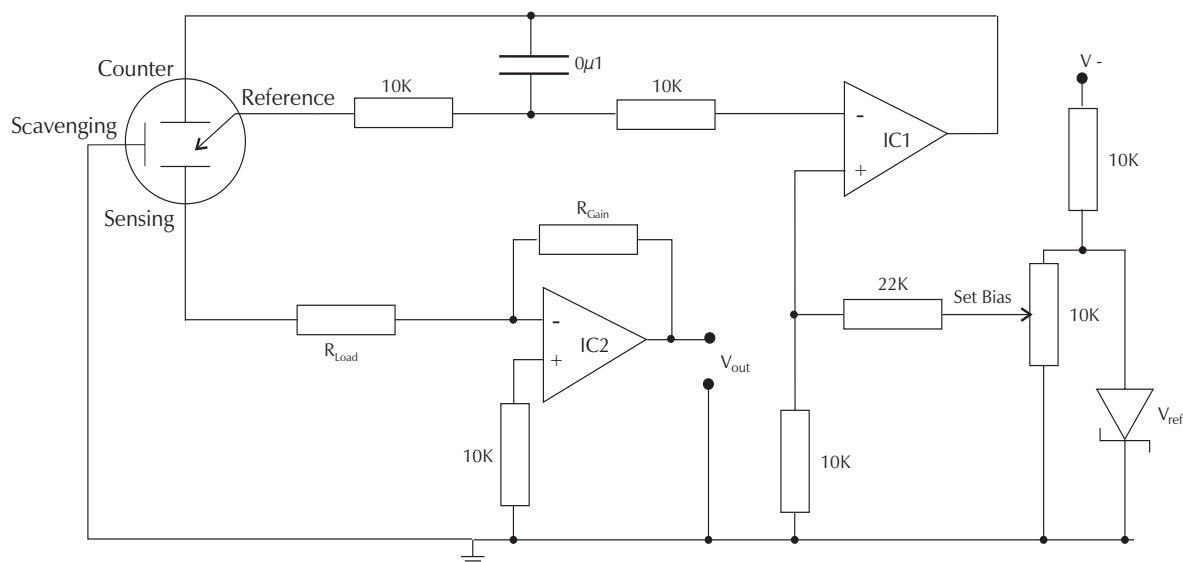

The A3NFX CiTiceL incorporates a fourth, "scavenging," electrode which may be connected to the instrument ground. In a normal 3-electrode sensor the products of NO oxidation can interfere with the potential of the sensor's reference electrode and possibly cause non-linearity of the signal and non-repeatability. This is especially the case in applications where the sensor is exposed repeatedly to high concentrations of nitric oxide. The "scavenging" electrode helps overcome this problem by chemically reacting the products of nitric oxide oxidation.

Every effort has been made to ensure the accuracy of this document at the time of printing. In accordance with the company's policy of continued product improvement City Technology Limited reserves the right to make product changes without notice. No liability is accepted for any consequential losses, injury or damage resulting from the use of this document or from any omissions or errors herein. The data is given for guidance only. It does not constitute a specification or an offer for sale. The products are always subject to a programme of improvement and testing which may result in some changes in the characteristics quoted. As the products may be used by the client in circumstances beyond the knowledge and control of City Technology Limited, we cannot give any warranty as to the relevance of these particulars to an application. It is the clients' responsibility to carry out the necessary tests to determine the usefulness of the products and to ensure their safety of operation in a particular application. Performance characteristics on this data sheet outline the performance of newly supplied sensors. Output signal can drift below the lower limit over time.