



AO3 CiTiceL[®]

with jack socket connector

Performance Characteristics

Output	9 - 13mV in Air
Range	0-100% O ₂
Resolution	0.01% O ₂
Expected Operating Life	360000%O ₂ hrs at 20°C 286000%O ₂ hrs at 40°C or 2 years in air at STP
T₉₀ Response Time	<5 seconds
T_{99.5} Response Time*	<40 seconds
Signal in 100%O₂	100±1%
Linearity	Linear 0-100% O ₂
Zero Offset	<20µV
Temperature Range	-20°C to +50°C
Temperature Compensation	<2% variation from 0°C to 40°C (see graph)
Differential Pressure Range	0-500mbar Max
Absolute Pressure Range	500-2000mbar
Relative Humidity Range	0 to 99% non-condensing
Long Term Output Drift	<10% signal loss/year
Recommended Load Resistor	Min 10KΩ
Warranty Period	12 month from date of despatch

* T_{99.5} response is equivalent to a change in concentration from 20.9% O₂ to 0.1% O₂
 N.B. All performance data is based on conditions at 20°C, 50%RH, and 1013mBar

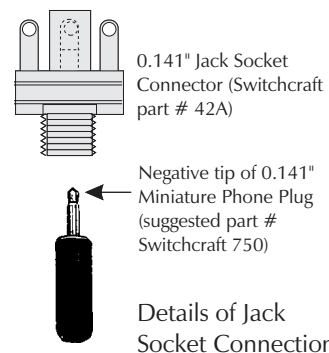
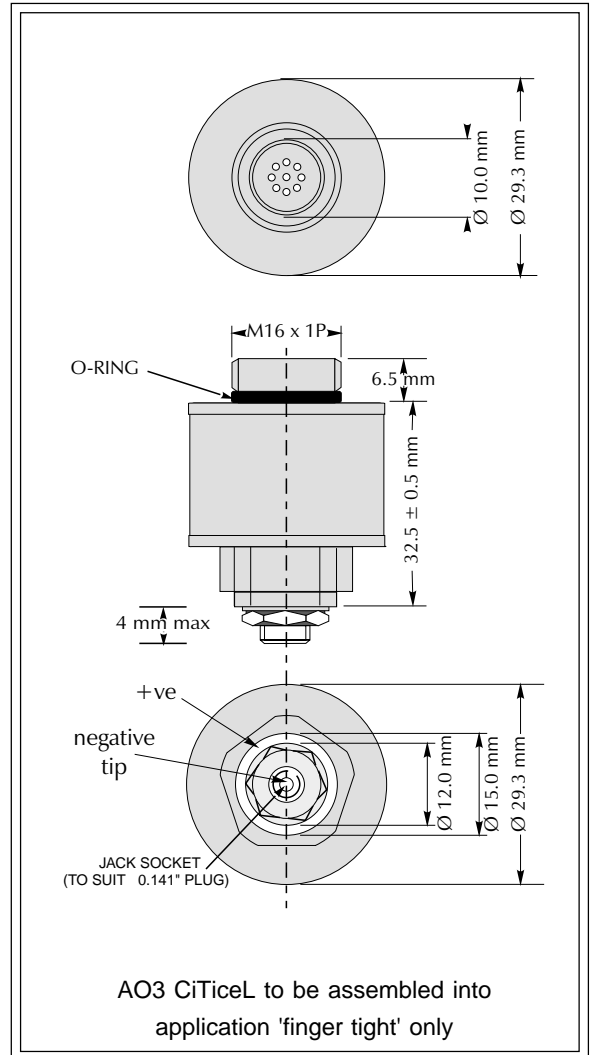



Temperature Behaviour

The output of an AO3 CiTiceL varies with gradual changes in temperature, but incorporates a thermistor to compensate for these changes. The thermistor gives the AO3 a very stable output over a wide temperature range.

The graph below shows the typical output behaviour of AO3 sensors over the range 0°C to +40°C.

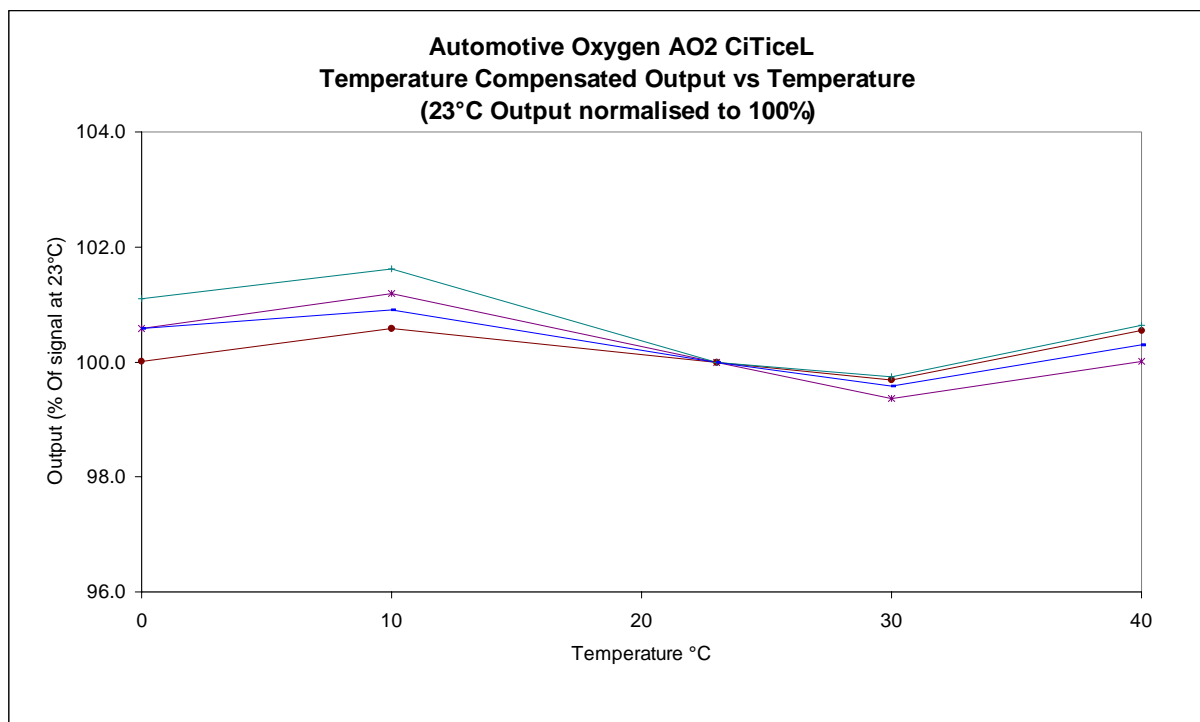

Cross-sensitivity

The AO3 has been tested for cross-sensitivity to a number of gases likely to be present in an automotive exhaust sample. The gas concentrations used and the response of the AO3 have been summarised below.

Gas	AO3 Output (%O ₂ equivalent)	Gas	AO3 Output (%O ₂ equivalent)
16%CO ₂ / Balance N ₂	<0.01	6%CO / Balance N ₂	<0.002
5% H ₂ / Balance N ₂	<0.001	3000ppm NO / Balance N ₂	<0.002
2000ppm n-hexane / Balance N ₂	<0.01		

These figures show that of the gases tested none show a sufficiently large cross-sensitivity to cause any inaccuracy in readings. In addition the baseline was unaffected by exposure to these gases.

Every effort has been made to ensure the accuracy of this document at the time of printing. In accordance with the company's policy of continued product improvement City Technology Limited reserves the right to make product changes without notice. No liability is accepted for any consequential losses, injury or damage resulting from the use of this document or from any omissions or errors herein. The data is given for guidance only. It does not constitute a specification or an offer for sale. The products are always subject to a programme of improvement and testing which may result in some changes in the characteristics quoted. As the products may be used by the client in circumstances beyond the knowledge and control of City Technology Limited, we cannot give any warranty as to the relevance of these particulars to an application. It is the clients' responsibility to carry out the necessary tests to determine the usefulness of the products and to ensure their safety of operation in a particular application.

Performance characteristics on this data sheet outline the performance of newly supplied sensors. Output signal can drift below the lower limit over time.