



NX3 CiTiceL[®]

For repair grade market

Performance Characteristics

Nominal Range	0-5000ppm
Inboard Filter	To remove effect of SO ₂ in gas stream
Expected Operating Life	Two years in air
Output Signal	0.05 ± 0.01 µA/ppm
Resolution	1ppm
Temperature Range	-20°C to +55°C
Pressure Range	800 - 1100mBar
Pressure Coefficient	0.01% signal/mBar
T₉₅ Response Time	<15 seconds
Relative Humidity Range	15 to 90% non-condensing
Typical Baseline Range (pure air)	0 to +12ppm equivalent
Maximum Zero Shift (+20°C to +40°C)	30ppm equivalent
Long Term Output Drift	<5% signal loss/year
Recommended Load Resistor	10 Ω
Bias Voltage	+300mV
Repeatability	2% of signal
Output Linearity	Linear

N.B. All performance data is based on conditions at 20°C, 50%RH, and 1013mBar

Physical Characteristics

Weight	32g
Position Sensitivity	None
Storage Life	Six months in CTL container
Recommended Storage Temperature	Avoid excessive heat and cold
Warranty Period	12 months from date of despatch

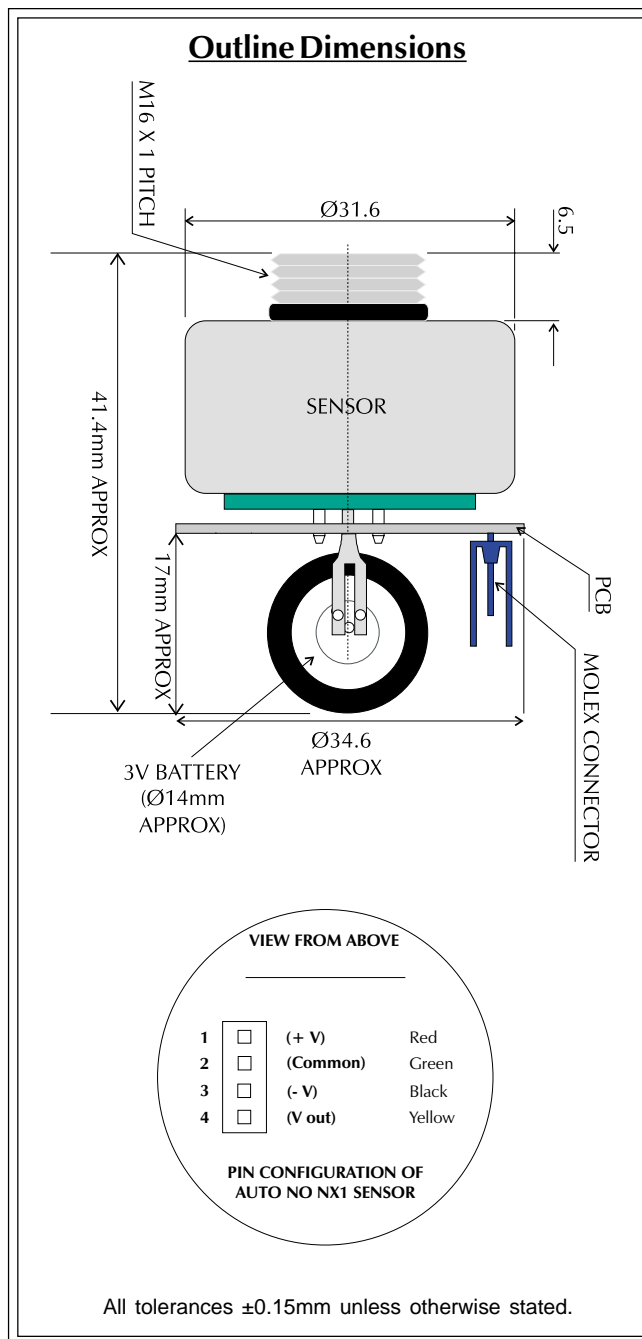

Automotive NX3 CiTiceL [®] Part Details	
MOLEX HEADER (0.100"/2.54mm)	Molex Part Number 22-29-2041
CRIMP TERMINAL HOUSING (MATING PART)	Molex Part Number 22-01-2045



Recommended External Circuit for Sensor

Note: All resistors 1% unless indicated

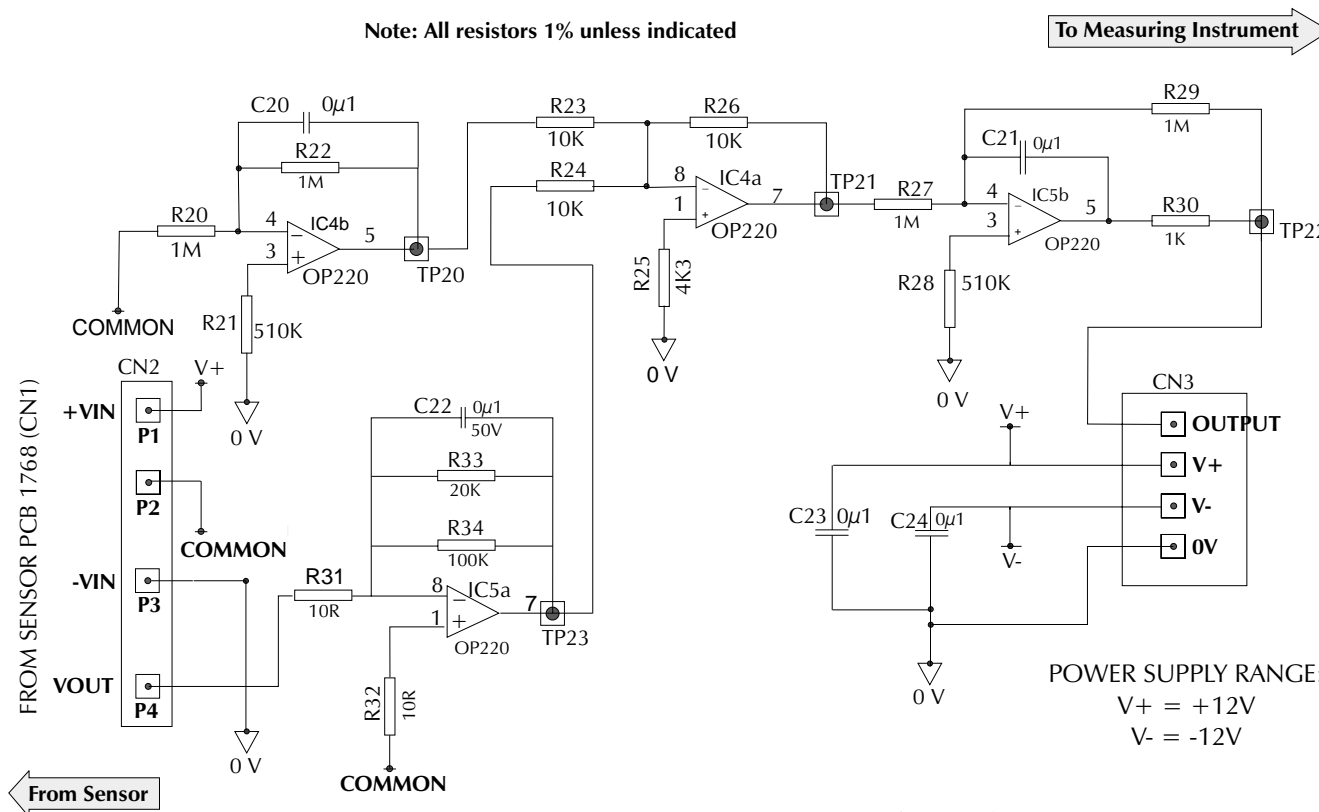

Doc. Ref.:nx1ext.cdr
 Issue No.:09 June, 1998

Every effort has been made to ensure the accuracy of this document at the time of printing. In accordance with the company's policy of continued product improvement City Technology Limited reserves the right to make product changes without notice. No liability is accepted for any consequential losses, injury or damage resulting from the use of this document or from any omissions or errors herein. The data is given for guidance only. It does not constitute a specification or an offer for sale. The products are always subject to a programme of improvement and testing which may result in some changes in the characteristics quoted. As the products may be used by the client in circumstances beyond the knowledge and control of City Technology Limited, we cannot give any warranty as to the relevance of these particulars to an application. It is the clients' responsibility to carry out the necessary tests to determine the usefulness of the products and to ensure their safety of operation in a particular application.

Performance characteristics on this data sheet outline the performance of newly supplied sensors. Output signal can drift below the lower limit over time.