

Product Specification of:

O₂ - Scuba Diving Sensor**Type : D-02**

Part. No.: 41 00 52

Key Features: single cathode galvanic fuel cell featuring an extra water repellent head space, fits to Draeger Oxygauge

All characteristics are based on conditions at 25°C, 50% RH and 1013 hPa

Electrical Connector:	gold-plated slip rings
Measurement Range:	0 to 100 Vol. %
Nominal Sensor Life:	> 500, 000 Vol. % h
Expected Operating Life:	< 3 years @ ambient air
Output Signal:	14 to 20 mV @ dry ambient air, 300 Ohm load
Response Time t_{90} :	< 12 s
Drift:	< 1% volume O ₂ / month @ air
Operating Temperature:	0 to 45°C
Pressure Range:	600 to 1750 hPa
Linearity Error:	< 2% @ 100% O ₂ applied for 5 min
Zero Offset Voltage:	< 200 μ V in 100% N ₂ , applied for 5 min
Influence of Humidity:	-0.03% rel. O ₂ reading per % RH
Recommended Load Resistor:	\geq 10 Ohm
Interferences:	none to He, H ₂ and CO

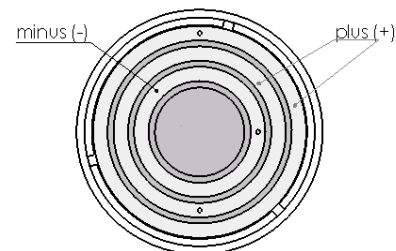
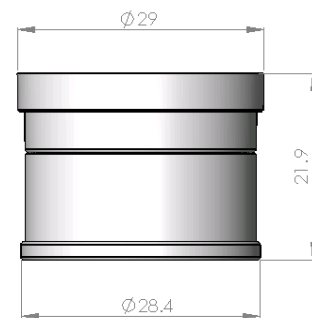
Tolerance: \pm 0.15 mm**Storage Conditions**

Temperature Range:	recommended: 5 to 30°C maximum: - 20 to 50°C
Ambient Pressure:	600 to 1750 hPa
Humidity:	up to 100% RH
Shelf Life:	< 6 months
Weight:	approximately 20 g
Material in contact with media:	PA, PPS, PTFE, stainless steel
Warranty Period:	12 months
Housing Color:	white

This data sheet is subject to change without prior notice!

[D-02 Rev01-05.doc]

page 1/1

IT Dr. Gambert GmbH, Hinter dem Chor 21, 23966 Wismar, GermanyTel.: +49 (0) 3841 22 00 50, Fax: +49 (0) 3841 22 00 522, sales@it-wismar.de, www.it-wismar.de