

Product Specification of:

O₂ - Scuba Diving Sensor**Type: D- 08**

Part. No.: 41 00 58

Key Features: galvanic fuel cell featuring an extra water repellent head space, fits to Analox's Mini O₂ and mini O₂ DII, UBS, OBS

All characteristics are based on conditions at 25°C, 50% RH and 1013 hPa

Electrical Connector:	2-pin Molex on wire
Measurement Range:	0 to 100 Vol. %
Nominal Sensor Life:	> 500 000 Vol. % h
Expected Operating Life:	< 3 years @ ambient air
Output Signal:	22 to 28 mV @ dry ambient air
Response Time t ₉₀ :	< 5 s
Drift:	< 1% volume O ₂ / month @ air
Operating Temperature:	0 to 45°C
Pressure Range:	600 to 1750 hPa
Linearity Error:	< 2% of full scale @ const. pressure, temperature
Zero Offset Voltage:	< 150 µV in 100% N ₂ , applied for 1 min
Influence of Humidity:	-0.03% rel. O ₂ reading per % RH
Recommended Load Resistor:	≥ 10 kOhm
Temperature Compensation:	NTC
Interferences:	none to He, H ₂ and CO

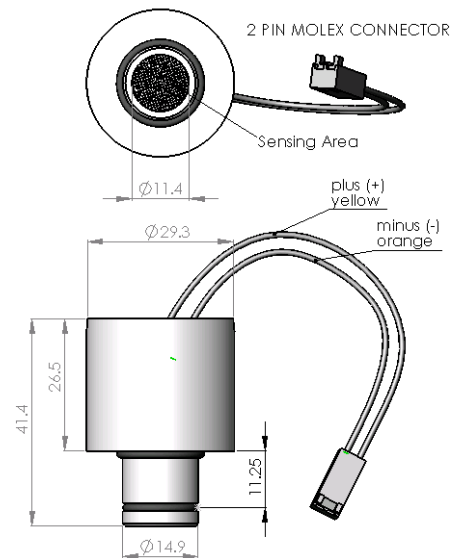

Tolerance: ± 0.15 mm

Storage Conditions

Temperature Range:	recommended: 5 to 30°C
	maximum: - 20 to 50°C
Ambient Pressure:	600 to 1750 hPa
Humidity:	up to 100% RH
Shelf Life:	< 6 months
Weight:	approximately 27 g
Material in contact with media:	PA, PPS, PTFE, stainless steel
Warranty Period:	12 months
Housing Color:	white

This data sheet is subject to changes without prior notice!

[D-08 Rev. 01-05.doc]

page 1 / 1

IT Dr. Gambert GmbH, Hinter dem Chor 21, 23966 Wismar, GermanyTel.: +49 (0) 3841 22 00 50, Fax: +49 (0) 3841 22 00 522, sales@it-wismar.de, www.it-wismar.de